



**NEW EXHAUST SYSTEM ASSY.
273076 - 125 Junior MAX, 125 MAX and 273118 - 125 MAX DD2**

Dear Service Center/Dealer,

We are proud to inform you about new exhaust systems introduced into engine serial production. The fixation of the after muffler to the exhaust pipe has been changed to minimize the risk of cracks in the exhaust system.

The after muffler is no more welded directly to the exhaust pipe (just on the 180°elbow) but fixed with 2 springs (238 940) to the exhaust pipe.

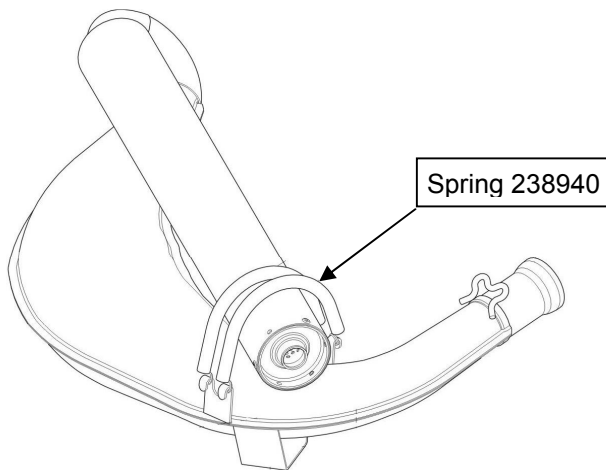

273118 - 125 MAX DD2

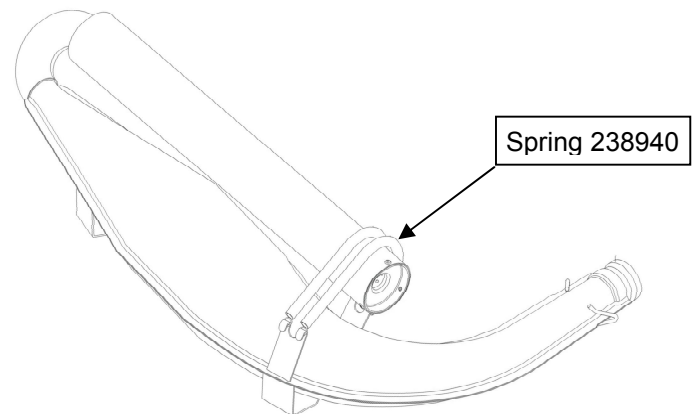

273076 - 125 Junior MAX and 125 MAX

The new exhaust system is convertible to the old exhaust system - engine performance retained unchanged.

Introduction into engine serial production

125 MAX and 125 Junior MAX

As of engine serial no. 8353312

125 MAX DD2

As of engine serial no. 8354220

ROTAX MAX Challenge

Both configurations (old and new) of exhaust systems are legal to be used in the ROTAX MAX Challenge
(see technical regulation <http://www.maxchallenge-rotax.com/regulations/technical.html>).

Warranty claims for exhaust systems

For our correct analysis of the warranty claims we ask you to claim the correct part numbers. Failures of "old" exhaust systems, where the after muffler is welded to the exhaust pipe must be claimed with part no. 273 074 for 125 Junior MAX and 125 MAX and 273 116 – for 125 MAX DD2.

Technical deviation at exhaust system 273076

Due to wide tolerances, the supplier has supplied the first production lot of exhaust systems 273076 with a "short elbow".

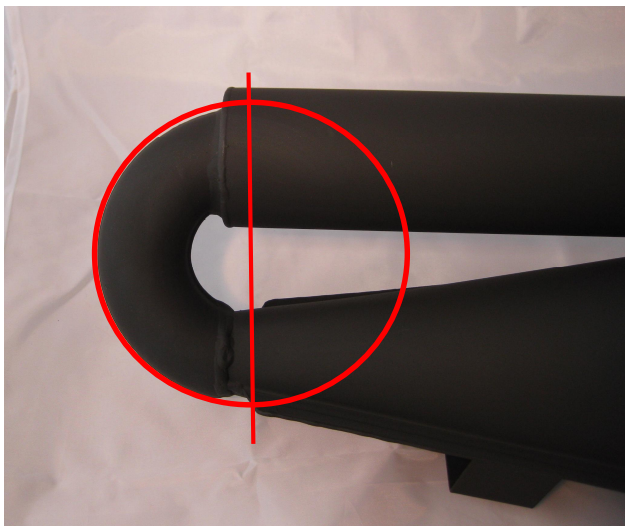

SHORT ELBOW



NORMAL ELBOW

This technical deviation has not influence on the function and/or performance of the engine and has therefore been accepted to be supplied to the market.

The next production lot will be again supplied with the normal elbow.

Communication schedule

On **2010.03.05**, "CUSTOMER INFO" has to be published at NEWS on web-pages (will be also on ROTAX web page), direct mailings to final customers, ROTAX news board....

Attached you will find separate documents for the "CUSTOMER INFO" translation and distribution according to the communication schedule.

Best regards,

Martin Chloupek
BRP-Powertrain GmbH & Co KG